

PrimeLine™ Syringe Pumps

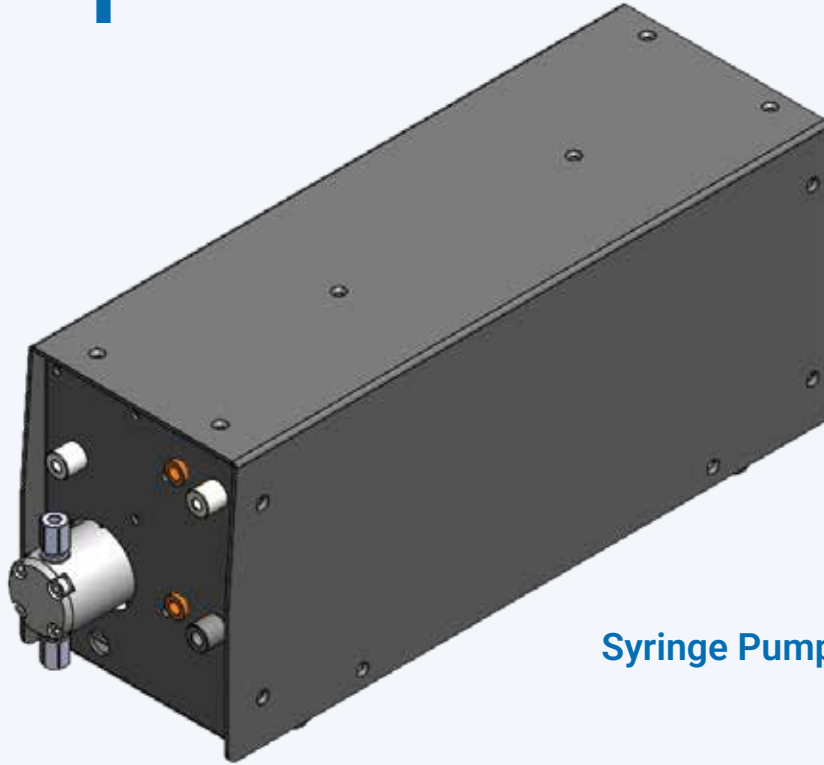

Syringe Pump in enclosure

Features:

- Superior flow stability
- Spring loaded check valves allow operation in horizontal or vertical mounting orientation
- 20,000 psi operating pressure (578 Series) & 9,000 psi (576 series)
- ASI nano check valve technology eliminates need for expensive rotary shear valves. NO MORE CONTAMINATES FROM WORN ROTOR SEALS!
- Windows based GUI for computer control (Modbus RTU using RS485)
- Pressurized fill system speeds refill and prevents cavitation
- Flow feedback option available for accurate and repeatable Nano flow operation
- Integrated wash pump option for buffers

ASI

ASI Model Syringe Pumps outperformed competitors in head-to-head engineering trials. Flow precision, was chosen as the critical evaluation metric by an independent engineering team. ASI was best-in-class for low flow ($\mu\text{L}/\text{min}.$) for pressures up to 9,000 PSI. Applications requiring such high precision includes: HPLC, LCMS, Sampling systems, Metering liquids and Sample preparation.

Unmatched flow precision at high pressure make the ASI Syringe Pump the top choice for design engineers

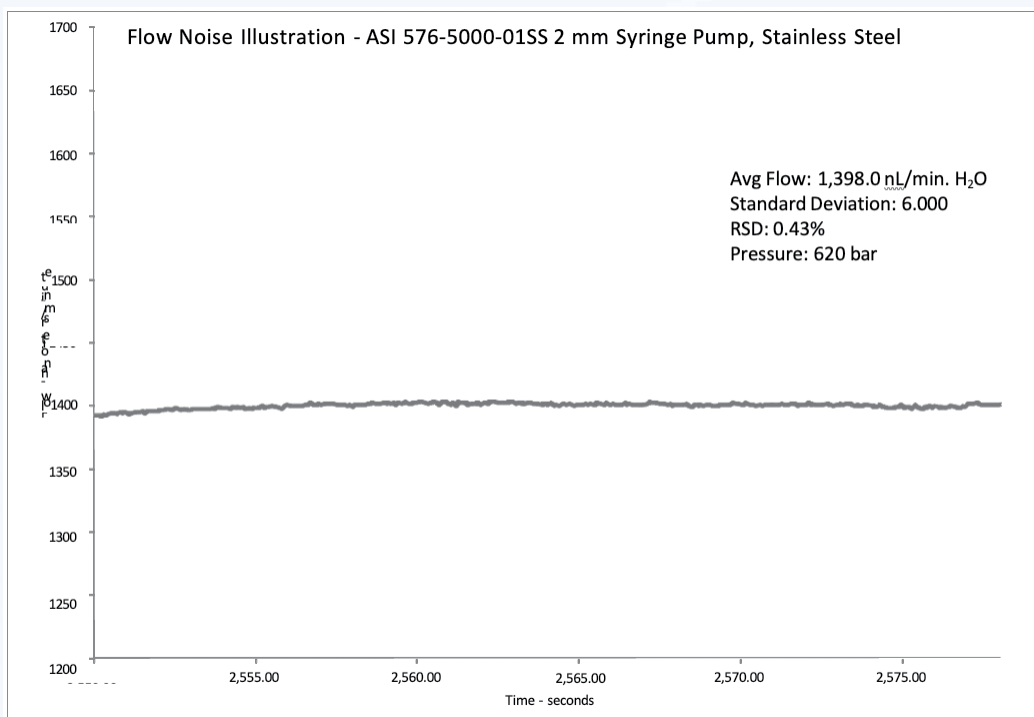
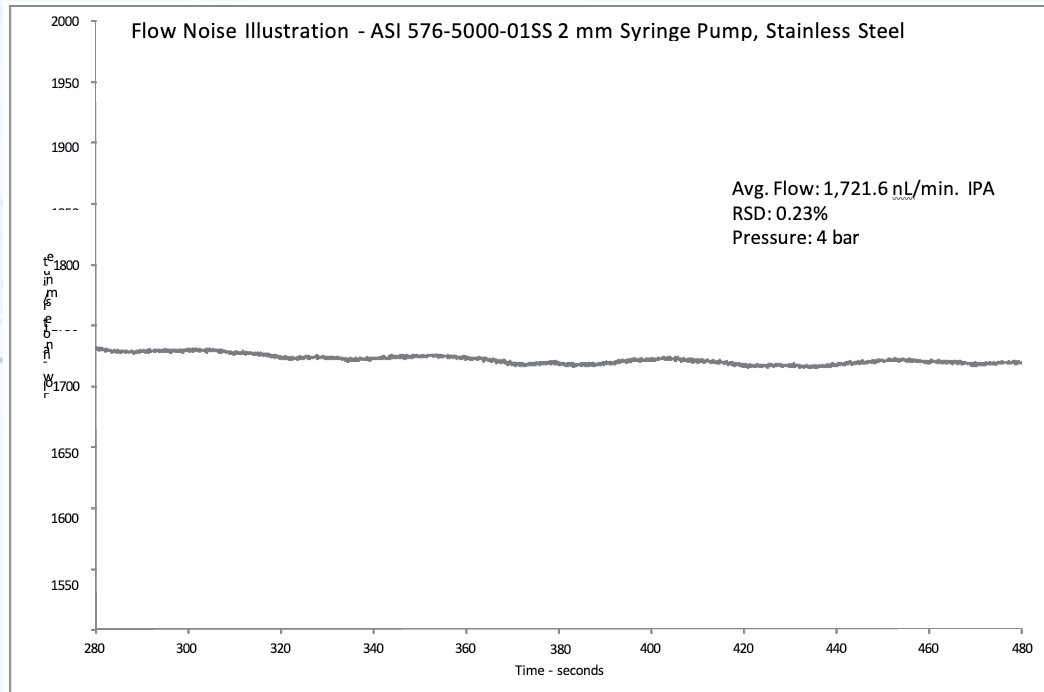

Competitor #1

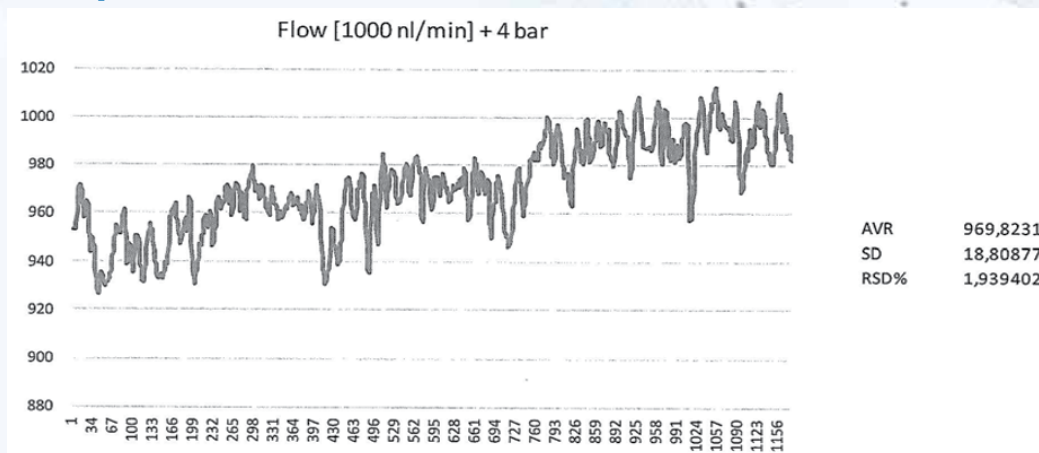

Competitor #2

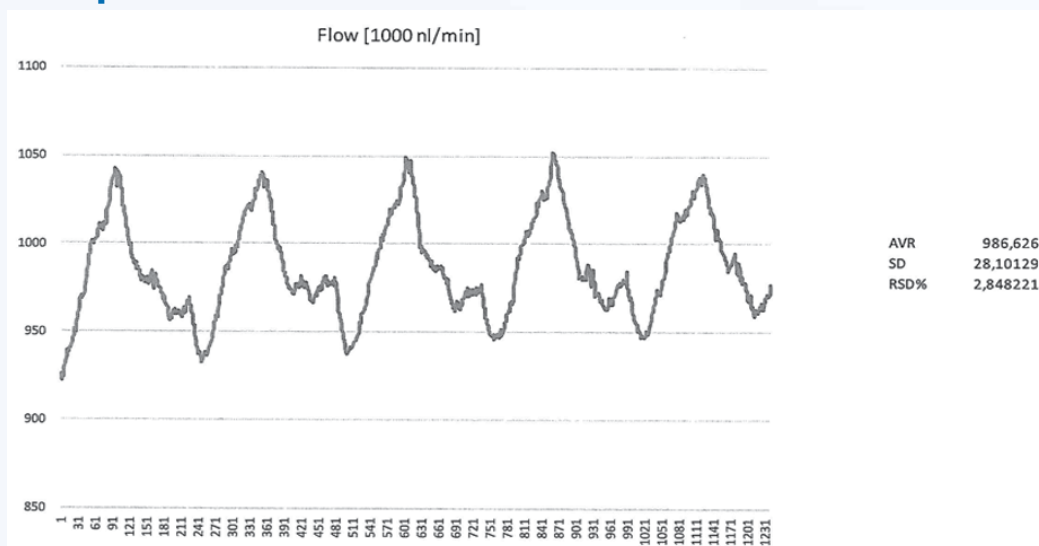

Specifications

Flow Range	50 nL/min. - 5 µL/min.
Max Pressure 578 series	20,000 PSI Max
Max Pressure 576 series	9,000 PSI Max
Accuracy	±2% @ 500 nL/min. @ 4,000 PSI MeOH*
Precision	0.25%, 500 nL/min. @ 4,000 PSI @ 20°C*
Flow Pulsation	.3% Δ P/P @ 4,000 PSI pressure
Dimension	4.0" W x 13.25" D x 5.75" H
Weight	16 lbs.
Power	AC 100 – 240 V 50/60 Hz, Fuse: 4A, 250 V
Motor	NEMA 17 triple stack step motor with motor drive & controller

* Using Flow feedback

OEM Inquiries are welcome!



Standard Check Valve Configuration

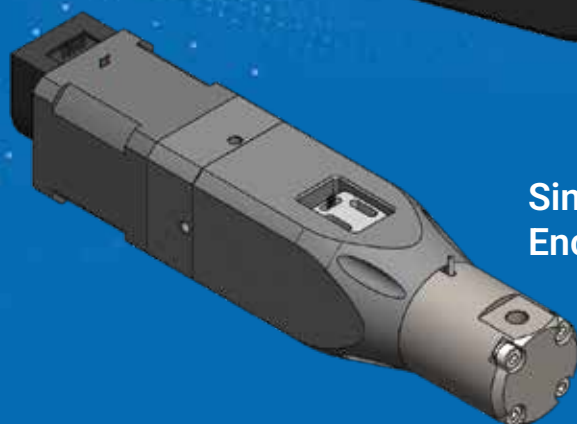

Single Port and Encoder options

The PrimeLine Syringe Pump without integral drive/ controller for stepper motor, check valves or other custom features are available, please contact us.

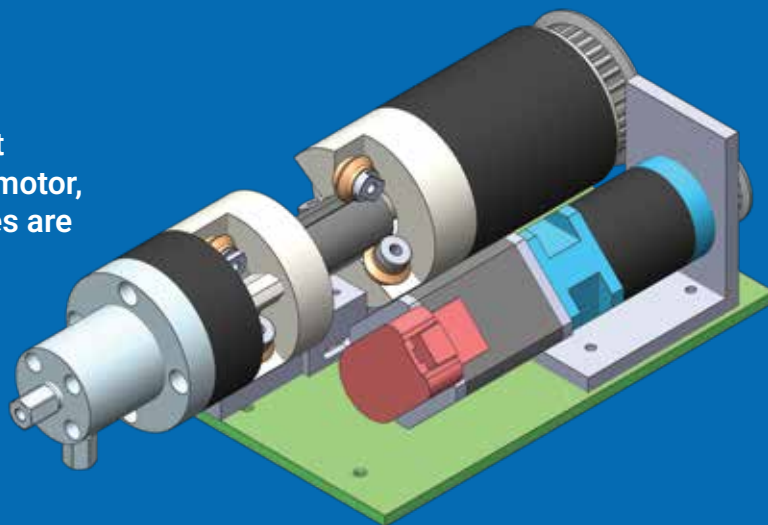

Analytical Scientific Instruments US, Inc.
3023 Research Drive Richmond CA 94806 USA
www.hplc-asi.com
Phone: 510-669-2250
Email: info@hplc-asi.com

ASI Analytical Scientific Instruments US

Copyright © 2026 ASI - Analytical Scientific Instruments US, Inc.
Rev. 05_11_2026